

Intelligent Load Shedding Need for a Fast and Optimal Solution

Shervin Shokooh
Operation Technology, Inc.
17 Goodyear, Suite 100
Irvine, CA 92618
USA

Tanuj Khandelwal
Operation Technology, Inc.
17 Goodyear, Suite 100
Irvine, CA 92618
USA

Dr. Farrokh Shokooh
Operation Technology, Inc.
17 Goodyear, Suite 100
Irvine, CA 92618
USA

Jacques Tastet
TECHNIP
Paris La Défense
France

Dr. JJ Dai
Operation Technology, Inc.
17 Goodyear, Suite 100
Irvine, CA 92618
USA

Abstract - To ensure system stability and availability during disturbances, industrial facilities equipped with on-site generation, generally utilize some type of load shedding scheme. In recent years, conventional under-frequency and PLC-based load shedding schemes have been integrated with computerized power management systems to provide an "automated" load shedding system. However, these automated solutions lack system operating knowledge and are still best-guess methods which typically result in excessive or insufficient load shedding. An intelligent load shedding system can provide faster and optimal load relief by utilizing actual operating conditions and knowledge of past system disturbances. This paper presents the need for an intelligent, automated load shedding system. Simulation of case studies for two industrial electrical networks are performed to demonstrate the advantages of an intelligent load shedding system over conventional load shedding methods from the design and operation perspectives.

Index Terms — Load Shedding (LS), Intelligent Load Shedding (ILS), Power System Transient Stability, Frequency Relay, Programmable Logic Controller (PLC), Power Management System

I. INTRODUCTION

It is an elementary case of 'power economics', load demand versus generation supply. When a power system is in stable operation at normal frequency, the total mechanical power input from the prime movers to the generators is equal to the sum of all running loads, plus all real power losses in the system.

The frequency conditions of the overall system will directly depend on the amount of active power that the generator prime movers could deliver to the system. Also, the stored energy of the prime movers plays an important roll on the system behavior. This stored energy varies drastically from gas, thermal, to hydro units.

For gradual increases in load, or sudden but mild overloads, unit governors will sense speed change and increase power input to the generator. Extra load is handled by the unused capacity of all available generators operating and synchronized to the system. If all generators are operating at maximum capacity, the spinning reserve is zero, and the governors may be powerless to relieve overloads.

Sudden and large changes in generation capacity through the loss of a generator or main inter-tie

impacts the dynamic response of the prime mover and can produce severe generation and load imbalance, resulting in rapid frequency decline. For some switching disturbances (that results in a loss of generation or system islanding condition), the cascading effects may be of the primary concern if the load shedding action is not set and timed correctly.

For instance, a short-circuit at the power station busbar may result in acceleration of the generator prime movers. When this occurs the speed regulator will then initiate closing of the fuel or gas inlet valve. After the fault has been cleared, the turbines face the impact of the load still connected. At this time the fuel or gas valves are closed resulting in difficult reacceleration conditions.

Gas turbines are very sensitive to critical speeds affecting their low pressure blades. These critical speeds may be close to the rated operating speed leaving a small margin on the allowed frequency range before reaching a protective trip. Typically a protective instantaneous low-speed trip on gas turbines may be set at 96% of the nominal system frequency.

Furthermore, system generation and stability are at risk as the frequency drops. This is specially the case for a thermal generation plant where power output mostly depends on motor-driven auxiliary loads, such as boiler feed water pumps, coal pulverizing, and draft fans. The drop in system frequency instigates a rapid fall of power output to the auxiliary loads, causing further reduction of the energy input to the turbine generator. This sequence of events further deteriorates the system frequency endangering the entire plant stability.

To halt the drop in frequency, it is necessary to intentionally, and automatically disconnect a portion of the load equal to or greater than the generation deficiency in order to achieve balanced power economics while maintaining system stability.

Automated load shedding systems are necessary for industrial power systems since sudden disturbances can plunge a system into a hazardous state much faster than an operator can react. These automated schemes must be designed and implemented to possess in-depth knowledge of system operating parameters and must rely on time sensitive monitoring and control communication networks in order to achieve the desired outcome of fast and optimal load shedding at the onset of a disturbance.

II. CONVENTIONAL LOAD SHEDDING APPROACH

This section is a review of load shedding techniques that have been devised over a number of years each having its own set of applications and drawbacks.

A. Breaker Interlock Load Shedding

This is the simplest method of carrying out load shedding. For this scheme, the circuit breaker interdependencies are arranged to operate based on hardwired trip signals from an intertie circuit breaker or a generator trip. This method is often used when the speed of the load shedding is critical. Even though, the execution of this scheme is fast, breaker interlock load shedding possesses a number of inherent drawbacks:

- Load shedding based on worst-case scenario
- Only one stage of load shedding
- Almost always, more load is shed than required
- Modifications to the system are costly

B. Under-Frequency Relay (81) Load Shedding

Guidelines for setting up a frequency load shedding are common to both large and small systems. The design methodology considers fixed load reduction at fixed system frequency levels. Upon reaching the frequency set point and expiration of pre-specified time delay, the frequency relay trips one or more load breakers. This cycle is repeated until the system frequency is recovered, e.g., 10% load reduction for every 0.5% frequency reduction. Since this method of load shedding can be totally independent of the system dynamics, total loss of the system is an assumed possibility. Additional drawbacks of this scheme are described below.

1) Slow Response Time

In addition to the time it takes for the frequency to reach the pre-defined settings, there is an intentional time delay setting to prevent nuisance tripping during frequency spikes. Time delay may be further prolonged due to the over-frequency condition that can occur during the fault.

Upon detection of frequency decay and expiration of set time delay, the frequency relay initiates the first stage of load shedding. If the amount of load shed was insufficient, the frequency continues to decay, activating the next stage of load shedding. Each additional stage introduces further delays in the load shedding process.

2) Incorrect / Excessive Load Shedding

The setting of each frequency relay is usually determined based on the most severe disturbance conditions, and most conservative generation and loading levels. This means excessive load shedding for the majority of conditions that are not as severe.

In response to a dip or rate-of-change in frequency, frequency relays operate a set of fixed circuit breakers, independent of their actual operating load. Some breakers might have a load that may be quite different than the value considered in the studies. Additionally, the sequence of operation of the breakers may not be correct and/or optimal.

3) Analysis Knowledge Is Always Lost

To determine the frequency relay settings requires simulation of hundreds of transient stability studies. The objective of this analysis is to find the minimum

fault clearing time and determine the minimum required load shedding by trial and error methods. The engineer performing the study learns the behavior of the system and can intuitively predict the response of the system under various operating conditions. However, the only study result utilized by the load shedding system is a set of frequency relay settings. All other pertinent analysis results, along with the engineer's knowledge of the system, are lost.

C. Programmable Logic Controller-Based Load Shedding

With a Programmable Logic Controller (PLC) scheme, load shedding is initiated based on the total load versus the number of generators online and/or detection of under-frequency conditions. Each substation PLC is programmed to initiate a trip signal to the appropriate feeder breakers to shed a preset sequence of loads. This static sequence is continued until the frequency returns to a normal, stable level.

A PLC-based load shedding scheme offers many advantages such as the use of a distributed network via the power management system, as well as an automated means of load relief. However, in such applications monitoring of the power system is limited to a portion of the network with the acquisition of scattered data. This drawback is further compounded by the implementation of pre-defined load priority tables at the PLC level that are executed sequentially to curtail blocks of load regardless of the dynamic changes in the system loading, generation, or operating configuration. The system-wide operating condition is often missing from the decision-making process resulting in insufficient or excessive load shedding. In addition, response time (time between the detection of the need for load shedding and action by the circuit breakers) during transient disturbances is often too long requiring even more load to be dropped.

III. INTELLIGENT LOAD SHEDDING APPROACH

An effective load shedding approach requires a comprehensive understanding of power system dynamics and process constraints, combined with knowledge of system disturbances. This required information is summarized below:

A. Pre-disturbance operating conditions:

- Total system load demand
- Total system power exchange to the grid
- Generation of each on-site unit
- Spinning reserve for each on-site unit
- Control settings for each running unit
- Settings and loading conditions for all major rotating machines
- System configurations (tie-line numbers, tie-line status and power transferring, bus-tie status and flows, transformers and feeder status and loading, loading of each load, especially loading for the sheddable loads, etc.)

B. Post-disturbance operating conditions:

- New system load demand
- Remaining generation from on-site generation
- Spinning reserve for each remaining unit
- Time duration to bring up the spinning reserve
- New system configurations

- Status, settings and loading conditions of the remaining major rotating machines
 - Status of each sheddable load
- C. *Nature and duration of the disturbance:*
- Electrical and/or Mechanical faults
 - Complete or partial loss of power grid connection
 - Complete or partial loss of on-site generation
 - Load addition (impact)
 - Location of disturbance
 - Duration of disturbance and its termination (self-clearance, fault isolation, protection device tripping, etc.)
 - Subsequent system disturbances
- D. *System transient response to a disturbance:*
- System frequency response (decay, rate-of-change, final frequency)
 - System voltage response
 - Rotor angle stability of each remaining unit
 - Operation of protective devices

A load shedding system, which can incorporate the above parameters into its calculation and decision making process, must possess certain intelligence. More and more of industrial facilities are being equipped with the modern data acquisition and monitoring system capable of detecting and reordering on-line operating data and disturbances conditions. In addition, power system modeling and simulation software tools have been significantly improved to perform various system analyses from a simple load flow study to more advanced studies such as transient stability analysis. In recent years, modern system-analysis software programs have been designed as a component of a larger power management system in order to perform system analysis using real-time data. In addition, techniques such as Neural Network (NN), Generic Algorithms (GA), Simulated Annealing (SA), Fuzzy Logic (FL), Expert Systems (ES), etc, have emerged in the field of power systems offering more effective problem solving, knowledge representation and reasoning, search, planning and action, for some highly non-linear problems, which often can not be solved using conventional techniques.

With the combination of such technological advances in power systems, an automated, intelligent, load shedding system can be designed to meet the following objectives:

- Map a complex, highly nonlinear, non-parametric, load shedding problem, to a finite space with a limited number of data collection points
- Automatic recall of system configuration, operating condition, and system response to disturbances
- Pattern recognition capability to predict system response to disturbances
- Systems knowledgebase trainable by user-defined cases
- Self-learning capability to new system changes
- Make prompt decisions regarding which loads to shed based on the online status of sheddable loads.
- Shed the minimum amount of load to maintain system stability

Illustrated in Fig. 1 is an Intelligent Load Shedding (ILS) scheme, which include several basic functional blocks defined below.

Knowledgebase utilizes carefully selected input and output data under different cases, based on off-line system studies and simulations. System dynamic responses including frequency variation are amongst the outputs of the knowledgebase.

Advanced Monitoring constantly surveys the system operating condition changes, and calculates tie-line flows, on-site generations, transformers and feeder loading as well as evaluates status of the sheddable loads.

Network Models contain system topology, connection information, and electrical properties of system components.

Trigger List is compiled based on pre-specified system disturbance types.

Load Shed Optimizer computes optimal load shedding tables corresponding to system changes.

Distributed Controls utilize PLCs to rapidly execute the load shedding actions based on detection of disturbance triggers from the system.

With the architecture described above, an ILS scheme provides the following benefits:

- Time-variant load shedding tables, which reflect true status, and loading conditions for the sheddable loads.
- Optimal combination of sheddable loads to maximize load preservation.
- Fast response to disturbance triggers (less than 100 ms in most cases).
- Environment to accelerate operator training with the ability to simulate and validate load shed decisions.

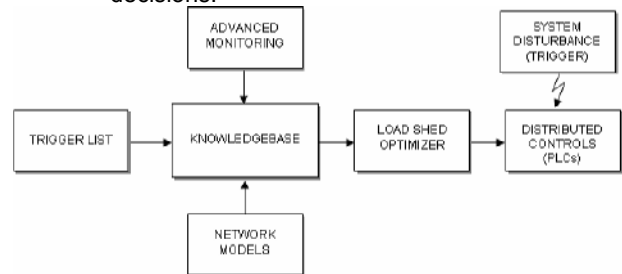

Fig. 1. ILS Scheme Function Block Diagram

Further details on this proposed scheme are explained in a companion paper titled "An Intelligent Load Shedding (ILS) System Technology Application in A Large Industrial Facility" to be presented at IEEE 2005 IAS Annual Meeting.

IV. NEED FOR A FAST AND OPTIMAL SOLUTION

To illustrate further the advantages of an ILS scheme over conventional under-frequency (81) and/or PLC-based (fixed logic) load shedding schemes, the following cases are considered and analyzed:

Case 1

Oil Refinery with Cogeneration

Comparison: PLC-based (Case 1a) vs. ILS (Case 1b)

ILS Objective: Fast Response (recovery)

Trigger: Electrical Fault (islanding from utility)

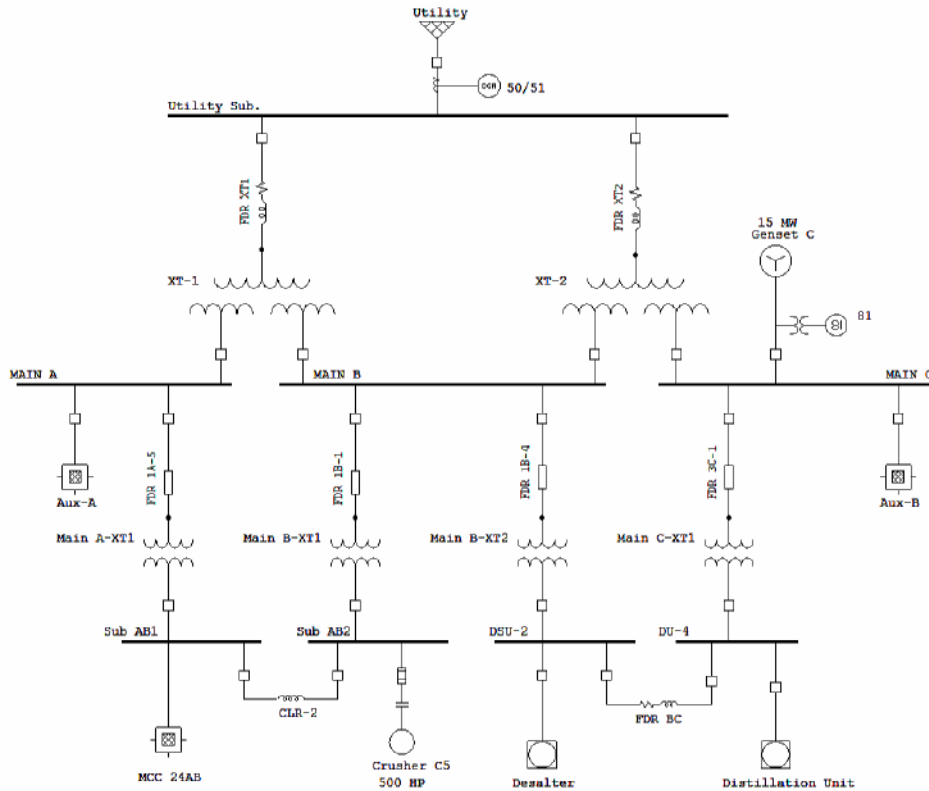

Fig. 2. Simplified One-line Diagram of an Oil Refining Facility – Case 1

Case 2

Islanded Oxygen Liquefaction Plant

Comparison: 81 (Case 2a) vs. ILS (Case 2b)

ILS Objective: Minimum (optimal) Load Shed

Trigger: Mechanical Trip (sudden loss of a generator resulting in reduced generation supply)

A. Case 1 – Need for Fast Load Shedding

This case addresses the problem of restoring the generation and load balance, for an industrial facility with on-site generation, in the event of disconnection from an external power grid. For such a scenario, shedding load is a necessary means used as a last controllable resort to avoid system collapse. Therefore, the execution of the load shedding system must be fast and reliable.

A computer simulation of an oil refinery electrical system is performed to illustrate the benefits of applying an ILS scheme over a conventional PLC-based load shedding scheme. Fig. 2 shows a simplified, electrical, one-line diagram of an oil refining facility, which describes an overview of the power network topology, including the generation and distribution system.

The internal electrical network supplies a total load of about 45 MW, and is constituted by the following:

- Substation interconnecting the internal electrical system to the power grid by two, three-winding transformers 34.5/13.8 kV rated at 20 MVA, supplying three main switchboards.
- Internal distribution system operating at 60 hertz organized into main distribution switchboards, rated at 13.8 kV and 4.16 kV, which supplies large MV motors and/or distribution feeders as

well as several low voltage distribution switchboards.

- Total generation of 15 MW obtained from one generator (Genset C).
- The plant is normally importing 23 MW from the utility, is supplemented by an onsite generator.
- Frequency relays are located throughout the system including the terminal bus of an onsite generator.

1) Case 1a. – PLC-Based Scheme Response

A PLC-based load shedding scheme utilizing frequency relay triggers was implemented as a retrofit to existing frequency relays to automate and speed up the overall load shedding sequence. A schematic of the hardware configuration and communication infrastructure is shown in Fig. 3. Continuous surveillance of the electrical network topology is performed by an online monitoring system. Automation of the load shedding system is constituted by a number of interconnected PLCs responsible for identification of the disturbance triggers up to the final trip actuation of circuit breakers. In this scheme, the disturbance triggers are hardwired from the frequency relays to the PLC.

There are a number of possible triggers, which would initiate load shedding in this system. Since the majority of the supplied power (>50%) is from the utility, loss of this source would be the most severe condition that the system would face, resulting in maximum amount of load being shed. As a part of the front-end system design, possible contingencies are evaluated, and required tables of loads to be shed are compiled.

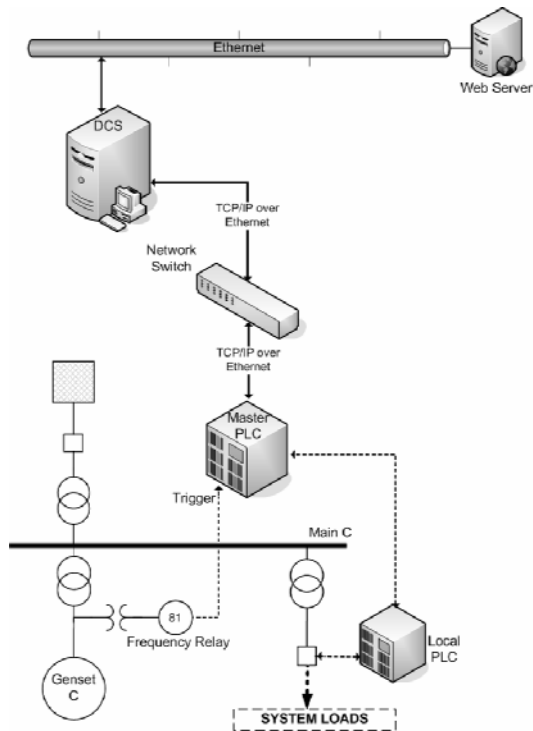

Fig. 3. Conventional PLC-Based LS System

The amount of load shed is determined primarily by power imbalance between required demand and available generation. If the operated load shedding is insufficient, additional loads will be dropped based on preset under-frequency relay stages.

Load shedding is organized into defined priority levels in order to minimize impact on plant processes. The sheddable load priority list for this system is shown in Table I.

TABLE I
SHEDDABLE LOAD PRIORITY LIST

Load Shed Priority	Load ID	MW Shed
1	Aux-B (Pump)	1.20
	MCC24AB (30% Load)	2.55
	Aux A (Pump)	2.00
	MCC24AB (30% Load)	2.55
2	Desalter #1	4.25
	Distillation Unit #1	3.40
	Distillation Unit #3	2.55
3	Desalter #2	4.25
	MCC24AB (40% Load)	4.25
	Distillation Unit #5	2.55
Total Load Shed		29.55

In the event of a sustained fault at (or close to) the Utility Sub (service entrance inter-tie), the overcurrent (50/51) relay at the substation trips the intertie circuit breakers (UTL-CB, CB-1 and CB-2), islanding the system from the power grid. Loss of intertie triggers system-wide frequency decay that can only be corrected if additional generation is brought online fast enough using spinning reserves, or rapid shedding of loads.

The frequency response of the surviving generator is shown in Fig. 4. The total time for system frequency recovery was approximately 240 cycles with a total

load rejection of 29.55 MW. This slow response time cannot be endured by most process units, and may result in further loss of loads due to process instability.

For the system described, the excessive recovery duration is due to the inherent limitations of PLC-based load shedding scheme utilizing trigger signals from frequency relays. Also, the processing time required in the PLC to calculate the load shedding sequence, further delays the overall response time whenever a load shed trigger is received.

2) Case 1b – ILS Scheme Response

Even though, automated PLC-based load shedding scheme benefits from the knowledge of actual operating information (via a power monitoring network), the scope of the power monitoring is limited to the sections of the system that are connected to the data acquisition network. This limitation is further compounded by the implementation of pre-defined load priority tables in the PLC.

These load priority tables are executed sequentially to curtail blocks of load regardless of the dynamic changes in loading, generation, or operating configuration. The system-wide operating conditions are often missing from the PLC's decision-making process, resulting in insufficient or excessive load shedding. In addition, response time (time between the detection of the need for load shedding, and action by the circuit breakers) during transient disturbances is often too long requiring even more load to be dropped.

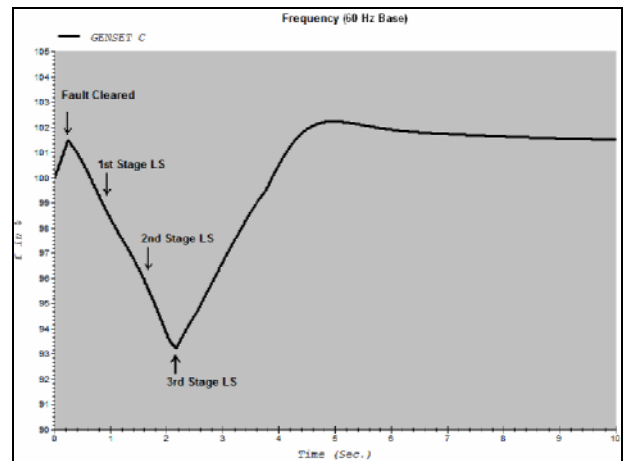

Fig. 4. Frequency Response of Islanded Generator

The inherent drawbacks of conventional PLC-based load shedding are overcome by an ILS scheme. The hardware configuration for the proposed ILS system is arranged as shown in Fig. 5.

Upon detection of the fault, the master PLC receives its trigger directly from overcurrent relay, rather than waiting for the frequency relay signal. Based on synchronized real-time measurements and operating topology, a pre-trained ILS knowledgebase can accurately calculate and determine the optimal amount of load (best combination of breakers) to be simultaneously shed for all possible triggers.

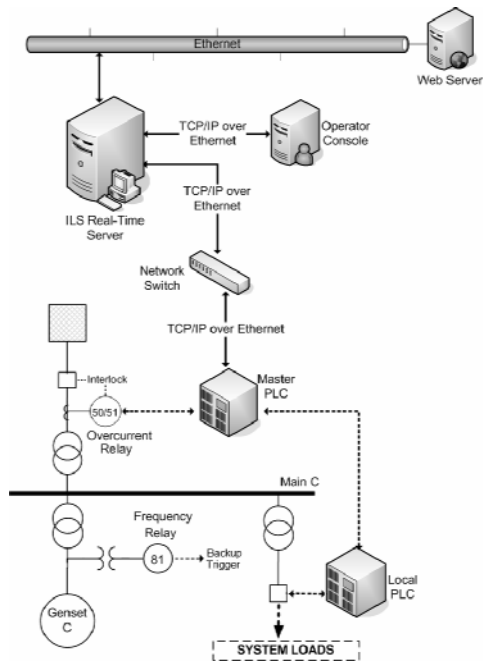

Fig. 5. ILS Communication Architecture

Unlike conventional PLC-based schemes that wait for the trigger signal to initiate the load shedding sequence evaluation in the PLC, an ILS scheme performs calculations at the server level (ILS real-time server) then downloads the time-variant load shedding tables to the PLCs on a continuous basis. Significant time saving is achieved using this technique.

Another advantage offered by performing the required calculations at the server level is the ability to update load priority lists, and user-defined logic directly from the operator console. This minimizes the downtime associated with removing and reprogramming the PLC whenever a logic change has to be made. A fail-safe or default priority table is also written to the PLC and is used in the event of communication failure between the ILS server and the PLC. Frequency relays are not removed, but utilized as backup protection.

A fault in the system is detected by overcurrent relays at $t=0$. The trigger, or contingency signal, is sent to the interlocked breaker within 0.5 cycles.

Within the same duration, the trigger is received by the master PLC. The master PLC has the latest dynamic load priority table as updated by the ILS server, based on user-defined logic, and known electrical network topology. Since no calculation is necessary within the PLC, 1.5 cycles of internal processing time is spent activating the PLC output to actuate load circuit breakers based on the dynamic load priority list. The load circuit breakers are 5 cycle breakers and the total load response time, from the time the contingency signal is detected to the time loads are shed, is about 7 cycles. A typical response time of an ILS system is shown in Fig. 6.

Table II lists the loads shed by ILS. The total load shed by an ILS system is 22.75 MW in approximately 8 cycles.

TABLE II
LOADS SHED BY ILS SCHEME

Load Shed Priority	Load ID	MW Shed
1	Aux-B (Pump)	1.20
	MCC24AB (LV Motors)	2.55
	Aux A (Pump)	2.00
2	MCC24AB (LV Motors)	2.55
	Desalter #1	4.25
	Distillation Unit #1	3.40
	Distillation Unit #3	2.55
3	Desalter #2	4.25
Total Load Shed		22.75

An overall 23% improvement (6.8 MW) is realized in the load amount preserved, due to the fast response time of the ILS scheme.

Note that the amount of load preservation would have been even higher if the load shed optimization routines were implemented for this ILS system. This feature of the ILS system is discussed in Case 2b of this paper.

Internal processing time of 1.5 cycles is spent by remote PLC to activate its output. For remote PLCs, the duration of the response may take up to 3.5 cycles depending upon the configuration of the communication network and location of the PLCs. Remote load breakers are opened 5 cycles later, resulting in a total load shedding time of 12 cycles.

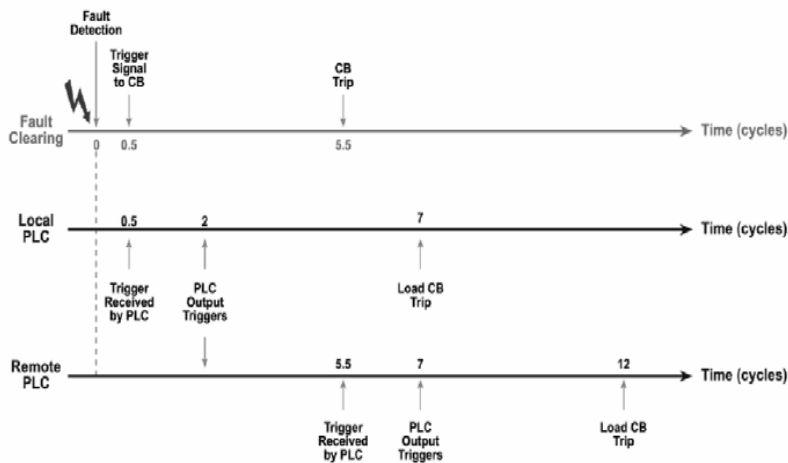

Fig. 6. ILS Response Time

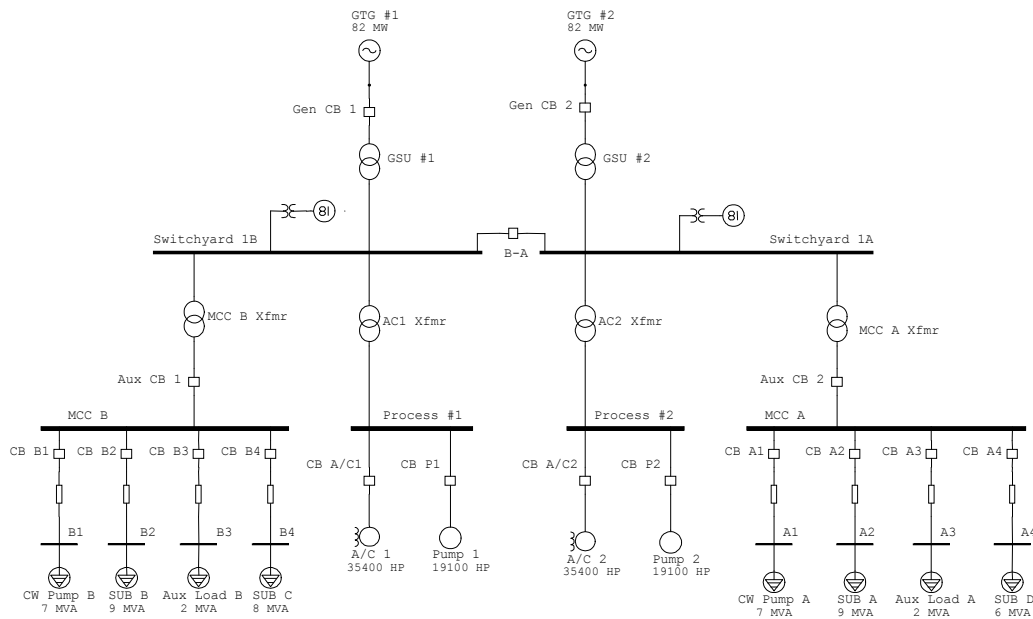

Fig. 7. Simplified One-Line Diagram of an Oxygen Liquefaction Plant - Case2

B. Case 2 – Need for Optimal Load Shedding

Case 2 illustrates an islanded industrial plant (no external power grid) utilizing an under-frequency relay based load-shedding scheme.

Fig. 7 shows the simplified one-line diagram of an oxygen liquefaction plant with two generators feeding the system load of 125 MW, and constituted by the following:

- Total generation of 160 MW supplied by two gas turbines; GTG #1 and GTG #2
- Step-up unit transformers for each generator rated at 90 MVA each, supplying the main switchyard
- Internal distribution system operating at 50 hertz organized into main distribution switchboards, rated at 10 kV with the aim of supplying large MV motors and/or distribution feeders into several low voltage distribution switchboards
- The main process motors (critical loads) are comprised of two synchronous air compressors; A/C 1, and A/C 2. Loss of an air compressor (A/C) unit would result in reduced production capacity
- Two induction motors supplying pump loads; Pump 1, and Pump 2
- Four sub-networks; Sub A, Sub B, Sub C, and Sub D comprised of several low voltage motors and lighting loads
- Two circulating water pumps; CW Pump A, and CW Pump B
- Auxiliary loads; Aux Load A, and Aux Load B

Consider an event where GTG #1, is suddenly tripped offline due to a mechanical fault (over-temperature, mechanical failure, etc). Loss of GTG #1 will impose increased load demand on the remaining power source (GTG #2). The load will continue to be supplied at the expense of decreasing speed of the rotating generator masses. The initial MW overload on the surviving generator is exactly equal to the lost MW generation.

Governor control on GTG #2 will work to correct the deficiency in system frequency. However, the gross imbalance of generation versus load demand, as well as the delay involved in reestablishing a new stable relationship in boilers, water flow, etc., calls for immediate load shedding in this system.

A pre-defined (static) load priority list is provided for the case where generation from GTG #1 is partially or completely lost. The applicable system loads have been compiled based on their criticality in order to minimize impact on operations and categorized as blocks of sheddable loads as shown in Table III.

TABLE III
LOAD SHED PRIORITY LIST
FOR LOSS OF GTG #1

Load Shed Priority	Load ID
1	Aux Load B
	CW Pump B
	Sub C
2	Sub B
	Sub D
	Sub A
3	Pump 1
	A/C 1

The response of the existing under-frequency relay load-shedding scheme is discussed in Case 2a.

1) Case 2a – Frequency Relay Scheme Response

Fig. 7 shows the location of the protection hardware for the existing frequency relay(s). Table IV provides a summary of the under-frequency relay settings that were determined based on load shedding studies. Load blocks are shed in stages to alleviate generator overload condition, with sufficient time delays to avoid nuisance trip due to transient frequency fluctuations. The delays shown in Table IV include the frequency relay, intentional delay (18 cycles), and the associate breaker opening time (7 cycles).

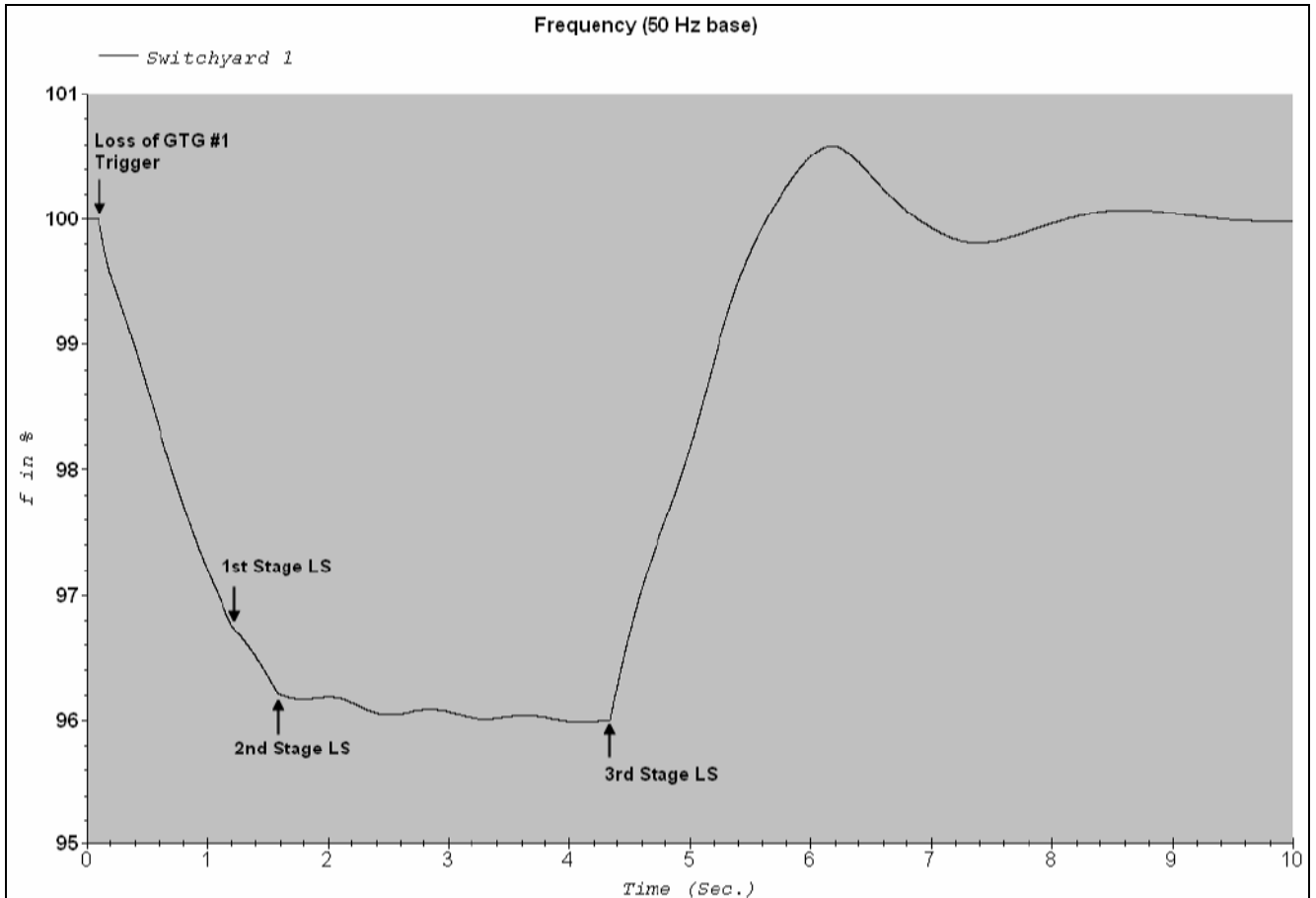

Fig. 8. Frequency Response for Load Shedding Stages

TABLE IV
UNDER-FREQUENCY RELAY
SETTINGS FOR LOSS OF GTG #1

Setting (%)	Hz	Total Delay (sec)	Load ID	MW Shed
98	49.0	0.5	Aux Load B	1.70
			CW Pump B	6.00
			Sub C	7.00
97	48.5	0.5	Sub B	7.65
			Sub D	5.00
			Sub A	7.65
96	48.0	0.5	A/C 1	27.00
			Pump 1	19.50
Total Load Shed				81.50

Upon loss of GTG #1, the system frequency plunges initiating the first stage of load shedding (98% setting) at around 1.2 seconds (60 cycles) after the detection of the trigger, as illustrated in Fig. 8. At this stage, a total of 14.7 MW are shed (CW Pump B, Aux Load B, and Sub C). The first load shedding stage is clearly insufficient to halt the frequency decline. The second stage of load shedding is set in motion approximately 0.383 seconds (19.15 cycles) after the first stage, dropping the next load block of 20.3 MW (Sub B, Sub D, and Sub A).

At this stage the system frequency continues to decline to 96% as an additional 15 MW are still required to be dropped in order to maintain the power

economy of the system. The last stage of load shedding is set off at about 2.754 seconds (137.7 cycles), after the second stage dropping air compressor Pump1 and A/C 1 (a total of 46.5 MW) resulting in reduced plant production capacity. Upon completion of the load shedding sequence, a total of 81.5 MW was dropped.

Frequency based load-shedding scheme, such as the one described above, use a pre-defined load priority list based on worst-case conditions. This static method sequentially drops the load as various pre-defined set points are reached. In summary, this methodology results in excessive load shedding.

2) Case 2b - ILS Scheme Response

The load-shedding scheme for Case 2a is revisited in order to minimize the impact on production in the event of a generator trip (or reduced generation) using an ILS scheme. The proposed intelligent load shedding scheme must be able to quickly recognize a generation deficiency, determine accurately the degree of overload, then precisely shed minimum, or optimum load required to restore system frequency to normal. As discussed previously, an ILS application involves gathering knowledge about possible disturbances, real-time operating conditions, and system topology. Fig. 9 shows the hardware configuration for the ILS scheme applied to this system.

One master PLC is installed at Switchyard 1. This master PLC is hardwired to two generators, and setup to receive triggers from GTG #1 and GTG #2. These triggers carry information pertinent to any mechanical

disturbance that would trip the generator. Load circuit breakers are connected to the same master PLC or the local PLC. Typically, local PLCs are used where long distances exist between generation and load centers.

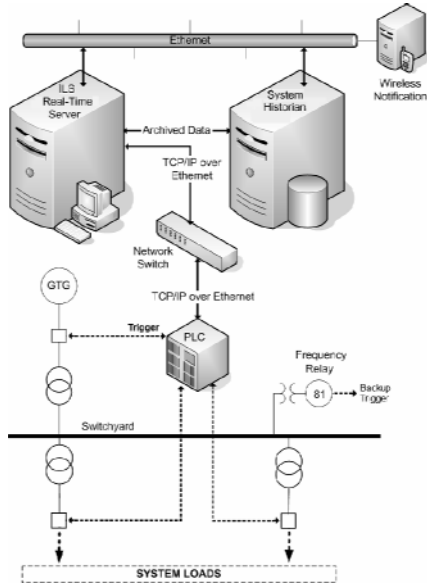

Fig. 9. ILS Communication Architecture

As a part of the ILS system, the existing load shedding priority list, as described in Table III, is further sub-categorized in groups for both critical and non-critical loads (where group 1 can be shed prior to group 2, and so on). The sorted load grouping is shown in Table V.

The ILS system calculates the required load to shed as the total generation capacity lost, minus the available spinning reserve ($82 - 30 = 52$ MW). ILS utilizes the pre-trained system knowledgebase combined with the grouped load priority list (Table V) to determine the optimal combination of loads to shed in the event of a GTG #1 generator trip. The load shedding priority tables are downloaded from the ILS server to the PLCs on continuous basis.

TABLE V
ILS LOAD GROUPING

Load Shed Priority	Group #	Load ID	MW
1	1	Aux Load B	1.70
	1	CW Pump B	6.00
	1	Sub C	7.00
2	2	Sub B	7.65
	2	Sub D	5.00
	2	Sub A	7.65
3	3	A/C 1	27.00
	3	Pump 1	19.50

Upon detection of disturbance trigger (trip of GTG #1), the local PLC initiate the shedding of the loads. Table VI shows the optimal load shedding to meet the generation and loading balance requirement.

For this scenario, all the loads in groups 1 and 2 were shed and the remaining generation deficiency of 17 MW ($52 - 35 = 17$ MW) was fulfilled by dropping Pump 1 (19.5 MW) from group 3. As a result of this optimal load shedding criteria, air compressor A/C 1 was preserved, minimizing the impact to production.

TABLE VI
OPTIMAL LOAD SHED BY ILS

Load Shed Priority	Group #	Load ID	MW Shed
1	1	Aux Load B	1.70
	1	CW Pump B	6.00
	1	Sub C	7.00
2	2	Sub B	7.65
	2	Sub D	5.00
	2	Sub A	7.65
3	3	A/C 1	(Preserved)
	3	Pump 1	19.50
Required Load Shed			52.00
Total Load Shed			54.50

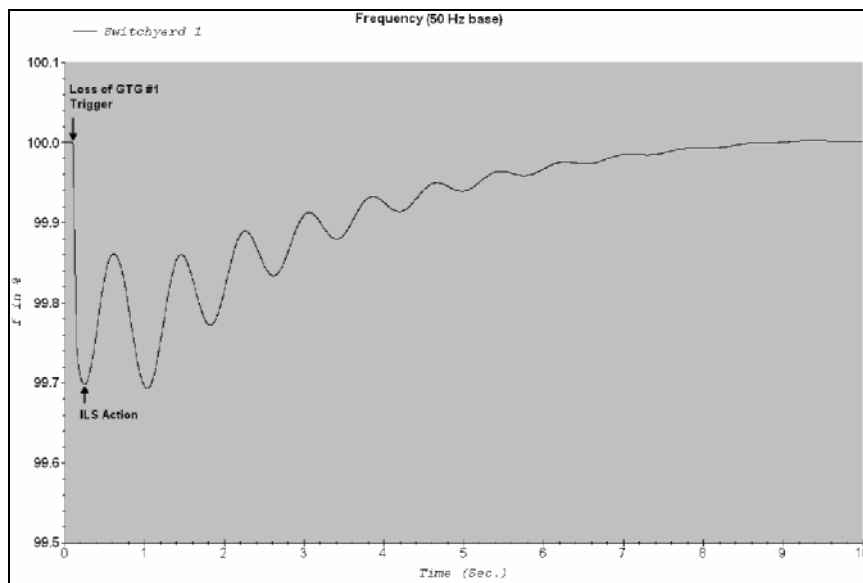

Fig. 10. Frequency Response with ILS Scheme

TABLE VII
COMPARISON OF LOAD SHEDDING SCHEMES

	Frequency Relay	PLC-Based	ILS
Total MW Shed	81.5	81.5	54.5

The 54.5 MW of load shed by ILS (as compared to 81.5 MW load drop by frequency, or PLC-based load-shedding systems) totals a load preservation of more than 33%. Fig. 10 shows the frequency response of the system frequency with this ILS scheme.

V. CONCLUSION

Load shedding serves as the ultimate guard that protects the power system from a disturbance-induced collapse. Normally, this critical load preservation is done with the use of under-frequency relaying and PLC-based schemes. Common drawbacks of these schemes include the lack of detailed system operating information such as pre- and post-disturbance data, system topology and configuration, generation and load distribution, type of disturbances, duration of the disturbances, and other pertinent information. This paper has introduced an intelligent, optimal, and fast load shedding technology referred to as ILS. ILS combines online data, equipment ratings, user-defined control logics, and a knowledgebase obtained from power system simulation studies, to continually update dynamic load shed tables. This system can perform optimal load shedding in less than 100 milliseconds from the initial occurrence of a disturbance. ILS technology has been successfully installed and operational at several industrial facilities.

VI. NOMENCLATURE

ILS	Intelligent Load Shedding
PLC	Programmable Logic Controller
NN	Neural Network
GA	Generic Algorithms
SA	Simulated Annealing
FL	Fuzzy Logic
ES	Expert Systems
LS	Load Shedding
Hz	Hertz
81	Frequency Relay Device Number
50/51	Overcurrent Relay Device Number

VII. REFERENCES

- [1] J. L. Blackburn, *Applied Protective Relaying, Principles and Applications*, New York, NY: Marcel Dekker, Inc. 1987
- [2] W.A. Elmore, *Protective Relaying Theory and Applications*, New York, NY: Marcel Deffker, Inc. 2004
- [3] Farrokh Shokoooh and JJ Dai, "An Intelligent Load Shedding (ILS) System Application in a Large Industrial Facility," IEEE IAS Conference Record, 2005
- [4] James McCalley and J.A. Pecas Lopes, "Using a Neural Network to Predict the Dynamic Frequency Response of a Power System to an Under-Frequency Load Shedding Scenario," IEEE Transactions on Industry Applications, pp 346-351, Jan 2000.
- [5] Load Shedding, Load Restoration and Generator Protection Using Solid-state and

Electromechanical Underfrequency Relays, GET-6449, General Electric Company, Philadelphia, PA.

[6] *Load Shedding – An Application Guide*, John Berdy, General Electric Company Electric Utility Engineering Operation, Schenectady, N.Y.

[7] *Protection of Steam Turbine – Generators During Abnormal Frequency Conditions*, J. Berdy & P.G. Brown, Electric Utility Engineering and L.E. Goff, Switchgear Engineering, General Electric Company, presented at Georgia Tech Protective Relaying Conference in 1974.

VIII. VITA

Shervin Shokoooh is a Senior Principal Engineer at Operation Technology, Inc. He served as a staff Electrical Engineer with Union Oil Company of California. He received a Bachelor degree in Electrical Engineering, and an MBA from the University of California, Irvine. He graduated from University of Southern California with an MS degree in Power Engineering. He is a registered Professional Engineer in the State of California.

Tanuj Khandelwal is a Senior Electrical Engineer at Operation Technology, Inc. He graduated from Bombay University in 1999 with a BE in Electronics and Telecommunications and California State University with an MS in Electrical Engineering. He is an active member of the IEEE sub-committees and working groups.

Dr. Farrokh Shokoooh has been a visiting lecturer at the University of California, Irvine, and served on the faculty at Louisiana State University. He was an Engineer for Fluor Corporation for seven years before founding Operation Technology, Inc. in 1986. He is a Fellow of IEEE, and active member of the IEEE subcommittees and working groups. He is a registered Professional Engineer in the state of California.

Jacques Tastet graduated from the EEIP School in France with an Engineering Degree in 1974. He worked for one year for the French EdF Distribution Board in the power distribution branch. He joined the Electrical Department of Technip in 1976 where he has provided team leadership for several major international oil and gas projects involving power generation and distribution. For the last 10 years, he has been the Head of Technip France Electrical Department. He has been designing and implementing power management systems in petrochemical facilities for the last 20 years.

Dr. JJ Dai is a Senior Principal Engineer at Operation Technology, Inc. He is a member of IEEE, a co-chairman of the Load Flow chapter and a main contributor of the Harmonics chapter of the IEEE Brown Book, a co-author of the IEEE Tutorial on Harmonic Modeling and Simulation, Secretary of the IEEE IAS Power System Analysis Subcommittee, and the past chairman of the IEEE IAS Abnormal Harmonic Phenomena Task Force. Dr. Dai is a registered Professional Engineer in the State of California.